

International Journal of Research in Pharmaceutical and Nano Sciences

Journal homepage: www.ijrpns.com



MEDICATED CHEWING GUM - AN OVERVIEW

S. Shahid Mohammed*¹ and M. Niranjan Babu²

¹*Department of Pharmaceutics, Seven Hills College of Pharmacy, Tirupati, Andhra Pradesh, India.

²Department of Pharmacognosy, Seven Hills College of Pharmacy, Tirupati, Andhra Pradesh, India.

ABSTRACT

Chewing gum has been used for centuries to clean the mouth or refresh the breath. The European Pharmacopoeia defined the intended use of medicated chewing gum (MCG) as non dissolving intraoral drug dosage form for local treatment of mouth diseases or for systemic delivery after absorption through the buccal mucosa or from the gastrointestinal tract. Medicated chewing gum has a history for about a century. Now-a-days it is considered to be a potential and convenient modified release drug delivery system which can be used in pain relief medication, smoking cessation, travel illness, freshening of breath, prevention of dental caries, alleviation of xerostomia, vitamin or mineral supplementations etc. Medicated chewing gums are prepared by using a water insoluble gum base with water soluble bulk portion. This formulation offers both local and systemic effects and has a range of advantages over conventional oral solid dosage forms. USP currently has no *in vitro* release testing apparatus for the evaluation and determination of drug release from the prepared chewing gums. But European Pharmacopoeia adopted a compendial apparatus to do so. Medicated chewing has drawn attention to the researchers as potential drug delivery system and it could be a commercial success in near future.

KEYWORDS

Systemic effects, Formulation, Medicated Chewing gum and Buccal Mucosa.

Author for Correspondence:

S. Shahid Mohammed,
Department of Pharmaceutics,
Seven Hills College of Pharmacy,
Tirupati, Andhra Pradesh, India.

Email: shahith_md@yahoo.co.in

INTRODUCTION

The Intra oral route is one of the more preferred routes of the drug administration as it is convenient and, with certain drugs, may provide a more rapid onset of action. During chewing the drug contained in the gum is released into the saliva. The released drug has got two fates; either it could be absorbed through the oral mucosa or may reach the stomach for GI absorption. In fact both these two fates may

occur simultaneously. So, medicated chewing gums offer both local and systemic effect. This drug delivery system offers two absorption pathways. Drug absorbed directly via the buccal membrane avoids metabolism in the gastrointestinal tract and thus the chance of first pass effect of the liver. As a result drug formulation as medicated chewing gum may require reduced dose compared to other oral drug delivery systems.

Intraoral dosage forms deliver the drug to the target sites for local or systemic drug delivery in the oral cavity include the following: buccal, sublingual, periodontal, periodontal pocket, peribuccal, per lingual, tongue (lingual), and Gum (gingival). The various types of intraoral dosage forms include liquid (solution, sprays, syrups, injection, etc) semisolids (ointment pastes, etc.) and solid dosage forms (quick-dissolve and slow-dissolve tablets, sublingual tablet, lozenges, films, filament, gums, patches, micro particles, drug delivery devices)^{1,2}. Intraoral drug delivery overcomes hepatic first-pass metabolism and promotes rapid systemic delivery with improved bioavailability with selected drugs having the required physicochemical and biopharmaceutical characteristics³. The first medicated chewing gum was introduced in the USA in 1924 with the brand name Aspergum⁴. But history suggests that chewing of non-food items for the purpose of pleasure is as old as ancient Egyptian, Mayan civilizations. In 1848, the first commercial chewing gum named State of Maine Pure Spruce Gum appeared in the market whereas the first patent was issued to Dr. W.F. Sample who was a dentist at Ohio in 1869⁵.

As chewing gums are taken orally and oral route of drug delivery is the most preferred route amongst the patient and clinicians due to various advantages it offers, in recent years chewing gums are considered to be friendly oral mucosal drug delivery systems^{6,7}. Chewing gum has been used to deliver therapeutic agents such as nicotine for smoking cessation therapy^{8,9}.

Definition

A medicated chewing gum is solid, single-dose preparation that is intended to be chewed for a

certain period of time, deliver the drug and which may contain one or more than one active pharmaceutical ingredient². The drug product is intended to be chewed in the oral cavity for a specific period of time, after which the insoluble gum base is discarded. Many therapeutic agents are absorbed in the oral cavity¹⁰.

Medicated chewing gums are defined by the European Pharmacopoeia and the guidelines for pharmaceutical dosage forms issued in 1991 by the Committee for Medicinal Products for Human Use (CPMP) as 'solid single dose preparations with a base consisting mainly of gum that are intended to be chewed but not to be swallowed, providing a slow steady release of the medicine contained. The drug product is intended to be chewed in the oral cavity for a specific period of time, after which the insoluble gum base is discarded^{11, 12}.

BENEFITS OF CHEWING GUM

Medicated chewing gums offer a range of advantages

- Chewing gum can be used without water, at any time, and everywhere.
- As the incorporated therapeutic agents are protected from oxygen, light, and water, product stability is good.
- Chewing gum can produce both local effects in the mouth (local delivery) and systemic effects after the active agents have been swallowed or (preferably) after they have been absorbed through the oral mucosa. The latter is of special interest with respect to bio-availability, since it avoids metabolism of the drug in the gastrointestinal tract and the so called liver-first-pass effect, because oral veins drain into the vena cava.
- Fast/rapid onset of action
- High bioavailability
- Pleasant taste
- Ready for use
- High acceptance by children and for patients who find swallowing tablets difficult

- Fewer side effects
- Effect on dry mouth (xerostomia)
- Product distinctiveness from a marketing perspective
- Excellent for acute medication
- Aspirin, Dimenhydrinate and Caffeine shows faster absorption through MCG than tablets^{4, 7, 13, and 14}.

DEMERITS OF MEDICATED CHEWING GUM

1. Risk of over dosage with MCG compared with chewable tablets or lozenges that can be consumed in a considerable number and within much shorter period of time.¹⁵
2. Sorbitol present in MCG formulation may cause flatulence, diarrhoea.
3. Additives in gum like flavouring agent, Cinnamon can cause Ulcers in oral cavity and Liquorice cause Hypertension¹⁶.
4. Chlorhexidine oromucosal application is limited to short term use because of its unpleasant taste and staining properties to teeth and tongue¹⁷.
5. Chewing gum has been shown to adhere to different degrees to enamel dentures and fillers¹⁸.
6. Prolonged chewing of gum may result in pain in facial muscles and ear ache in Children¹⁹.

ABSORPTION OF DRUG ACROSS THE ORAL MUCOSA

The oral cavity is point of entry for oral drug formulations but their contact with the oral mucosa is brief. So in order to take advantages of these properties or to treat the mucosa locally, these delivery system have been designed to prolong residence in this area. The total surface area available for drug absorption is quite limited being only approximately 100 cm². The oral cavity is rich in blood vessels and lymphatic, so rapid onset of action and high blood levels obtained quickly.

In many cases oral dosage form can result in the same availability as the same intravenous formulation, without need of aseptic preparation. Finally they share with transdermal system the

advantages that treatment can be rapidly stopped by removing dosage form. Ideally the plasma concentration versus time profile should resemble a square wave, similar to that seen after application of glycerol trinitrate patches, but this is not always achievable. In order to absorb orally, the drug must be dissolve in saliva. Extremely hydrophobic materials will not dissolve well and are likely to be swallowed intact unless a specialized delivery system is used to prevent them to mucosa²⁰.

IDEAL REQUIREMENTS FOR DRUG PROFILE

1. The drug should not have any type of disagreeable taste, this can affect patient compliance.
2. The particle size of the drug should be kept below approximately 100 m cm to avoid unpleasant gritty feeling during chewing.

Physico Chemical Properties of Drug

- High salivary solubility
- PH independent solubility
- Tasteless

Patient Related Factors

- Non toxic to oromucosa and salivary ducts
- Non carcinogenic
- Should not cause tooth decay
- Should not cause tooth decay and oromucosa staining
- Should not affect salivary flow rate^{21,22}.

MANUFACTURING PROCESSES

- Different methods employed for the manufacturing of CG can be broadly classified into three main classes namely

Conventional/ Traditional method (Melting or Fusion method)^{13, 25}

- Components of gum base are softened or melted and placed in a kettle mixer to which sweeteners, syrups, active ingredients and other excipient are added at a definite time. The gum is then sent through a series of rollers that forms into a thin, wide ribbon. During this process, a light coating of finely powdered sugar or sugar substitutes is added to keep the gum away from

sticking and to enhance the flavor. In a carefully controlled room, the gum is cooled for up to 48 hours. This allows the gum to set properly. Finally the gum is cut to the desired size and cooled at a carefully controlled temperature and humidity.

Limitations

- Elevated temperature used in melting restricts the use of this method for thermo labile drugs.
- Melting and mixing of highly viscous gum mass makes controlling of accuracy and uniformity of drug dose difficult.
- Lack of precise form, shape or weight of dosage form.
- Technology not so easily adaptable to incorporate the stringent manufacturing conditions required for production of pharmaceutical products.
- Such a chewing gum composition is difficult to form into chewing gum tablets because of their moisture content (2-8%). If attempted to grind and tablet such a composition would jam the grinding machine, stick to blades, screens adhere to punches and would be difficult to compress.

Cooling, Grinding and Tableting Method (Thermoliable)

- This method has been developed with an attempt to lower the moisture content and alleviate the problems mentioned in conventional method.
- Cooling and Grinding Method^{13, 26}. The CG composition (base) is cooled to a temperature at which the composition is sufficiently brittle and would remain brittle during the subsequent grinding step without adhesion to the grinding apparatus. The temperature required for cooling is determined in part by the composition of the CG and is easily determined empirically by observing the properties of the cooled chewing gum composition. Generally the temperature of the refrigerated mixture is around -15° C or lower.
- Amongst the various coolants like liquid nitrogen, hydrocarbon slush use of solid carbon dioxide is preferred as it can give temperatures as low as -78.5 ° C, it sublimates readily on

warming the mixture, is not absorbed by the chewing gum composition, does not interact adversely with the processing apparatus and does not leave behind any residue which may be undesirable or potentially hazardous. The refrigerated composition is then crushed or ground to obtain minute fragments of finely ground pieces of the composition.

- Alternatively, the steps of cooling the chewing gum composition can be combined into a single step. As an example, cooling the grinding apparatus itself which can be done by contacting the grinding apparatus with a coolant or by placing the grinding apparatus in a cooling jacket of liquid nitrogen or other cold liquid. For more efficient cooling, the chewing gum composition can be pre cooled prior to cooling to the refrigeration temperature.
- Sometimes a mixture of chewing gum composition, solid carbon dioxide and precipitated silica is ground in a mill grinder in the first step. Additional solid carbon dioxide and silica are added to the ground composition, and the composition is further ground in the second step. This two step grinding process advantageously keeps the chewing gum composition at a very low temperature.
- The presence of solid carbon dioxide also serves to enhance the efficiency of the grinding process. The same process can be made multiple by adding incorporating additional carbon dioxide and/or precipitated silica at each step. Certain additives can be added to the chewing gum composition to facilitate cooling, grinding and to achieve desired properties of chewing gum. These include use of anti-caking agent and grinding agent. Anti-caking agent like precipitated silicon dioxide helps to prevent agglomeration of the subsequently ground chewing gum particles. To prevent the gum from sticking to the grinding apparatus 2-8% by weight of grinding aid such as alkaline metal phosphate, an alkaline earth metal phosphate or maltodextrin can be incorporated.

Tabletting Method

Once the coolant has been removed from the powder, the powder can be mixed with other ingredients such as binders, lubricants, coating agents, sweeteners etc, all of which are compatible with the components of the chewing gum base in a suitable blender such as sigma mill or a high shear mixer. Alternatively a Fluidized Bed Reactor (FBR) can be used. The use of FBR is advantageous as it partially rebuilds the powder into granules, as well as coats the powder particles or granules with a coating agent thereby minimizing undesirable particle agglomeration. The granules so obtained can be mixed with anti adherents like talc. The mixture can be blended in a V type blender, screened & staged for compression. Compression can be carried out by any conventional process like punching. It requires equipment other than conventional tabletting equipment and requires careful monitoring of humidity during the tabletting process which is the major limitation, it requires equipment other than conventional tabletting equipment and requires careful monitoring of humidity during the tabletting process.

Direct compression method²⁶

- The manufacturing process can be accelerated if a directly compressible chewing gum excipient is available. The limitations of melting and freezing can be overcome by the use of these.
- Pharmagum, is one such compactable gum system developed by SPI Pharma. Pharmagum is a mixture of polyol(s) and or sugars with a chewing gum base. It is available as directly compressible powder, free flowing powder which can be compacted into a gum tablet using conventional tablet press thus enabling rapid and low cost development of a gum delivery system. It is manufactured under CGMP conditions and complies with Food Chemicals Codex specifications as well as with FDA, so they can be considered as "Generally regarded as safe" (GRAS).
- Pharmagum is available in three forms namely S, M and C. Pharmagum M has 50% greater gum base compared to Pharmagum S. Pharmagum S

consists primarily of gumbase and sorbitol. Pharmagum M contains gumbase, mannitol & Isomalt. Release of nicotine from directly compressible nicotine gum formulations and from Nicorette prepared by conventional methods have shown that use of Pharmagum in formulation showed a faster release rate. Formulations made with harmagum M & S are similar to tablet in appearance. Gums formed using compressible formulation are 10 times harder and crumble when pressure is applied resulting in faster release than conventional methods. Use of Pharmagum S, M and C enables formulators to utilize a gum.

APPLICATIONS²⁷⁻³²

Dental caries

- Prevention and cure of oral disease are targets for chewing gum formulations.
- It can control the release rate of active substances providing a prolonged local effect.
- It also re-elevates plaque pH which lowers intensity and frequency of dental caries.
- Fluoride containing gums have been useful in preventing dental caries in children and in adults with xerostomia.
- Chlorhexidine chewing gum can be used to treat gingivitis, periodontitis, oral and pharyngeal infections.
- It can also be used for inhibition of plaque growth.
- Chlorhexidine chewing gum offers numerous flexibility in its formulation as it gives less staining of the teeth and is distributed evenly in the oral cavity.
- The bitter taste of chlorhexidine can be masked quite well in a chewing gum formulation.

Systemic therapy

Pain- chewing gum can be used in treatment of minor pains, headache and muscular aches.

Smoking cessation- Chewing gum formulation containing nicotine and lobeline have been clinically tested as aids to smoking cessation.

Obesity- Active substances like chromium, guaran and caffeine are proved to be efficient in treating

obesity. Chromium is claimed to reduce craving for food due to an improved blood-glucose balance. Caffeine and guaran stimulate lipolysis and have a thermogenic effect (increased energy expenditure) and reduce feeling of hunger.

Other indications- Xerostomia, Allergy, Motion sickness, Acidity, Cold and Cough, Diabetes, Anxiety, etc are all indications for which chewing gum as drug delivery system could be beneficial.

QUALITY CONTROL³³

Test for Uniformity of Content

Unless otherwise prescribed or justified and authorized medicated chewing gum with content of 2 mg or less than 2 percent of the total mass of gum comply with test.

Uniformity of mass

Uncoated medicated chewing gum and unless otherwise justified and authorized coated medicated chewing gum comply with the test for uniformity of mass of single- dose preparations.

Drug release from medicated chewing gum

It has been reported commercially that the drug release from medicated chewing gum as per the specification given in European Pharmacopoeia and is determined by applying a mechanical kneading procedure to a piece of gum placed in a small chewing chamber containing a known volume of buffer solution.

Apparatus I: Chewing Gum Apparatus, Compendial-Ph. Eur

The chewing apparatus for medicated chewing gum was adopted by Ph. Eur. in 2000.³⁴ Figure 1 shows the construction of the apparatus. The chewing apparatus comprises a chewing chamber, two horizontal pistons, and a third vertical piston (tongue). The vertical piston operates alternatively with the two horizontal pistons and makes sure the gum stays in the right place between chews. If necessary, it is feasible to construct the machine so that at the end of the chew the horizontal pistons rotate around their own axes in opposite directions to each other to obtain maximum chewing. The working procedure of this chewing apparatus is described in Ph. Eur.^{34,35} Several studies have been

carried out using the Ph. Eur. Apparatus and the results indicate the methodology is rugged and reproducible.

Apparatus II: Alternative Chewing Gum Apparatus, Noncompendial—Wennergren

One of the noncompendial apparatus commercially available was designed by Wennergren.³⁶ The schematic representation of the Wennergren chewing apparatus is shown in Figure 2. The chewing procedure consists of reciprocations of the lower surface in combination with a shearing (twisting) movement of the upper surface that provides mastication of the chewing gum and at the same time adequate agitation of the test medium. The upper jaw has a flat surface that is parallel to the central part of the lower surface. The small brim of the lower surface is angled upwards (45 degrees) so that the lower surface functions as a small bowl with a flat bottom. This bowl prevents the chewing gum from sliding during mastication. Investigations of the performance of the chewing apparatus with multiple drug products were published by Wennergren et al.³⁶ The influences of different operational parameters of the chewing gum apparatus on drug release have been carefully investigated.³⁷

Drug release testing methodology

- Ph. Eur. has adopted an apparatus to determine the release rate from chewing gum formulations.⁶¹ The basic principle is a simple masticatory movement employed to simulate the chewing action on a piece of gum placed in a small chewing chamber containing a known volume of buffer solution at a given temperature.³⁸ The drug release rate is influenced by the chewing rate and angle, which provides the necessary shear force to expose new gum surfaces and is a requisite for further drug Release. The mechanism and kinetics of drug release from chewing gums have not yet been completely understood due to the complexity of the formulation itself. The transition from the inactive gum to the active dosage form is influenced by
 - Mechanical forces

- Temperature
- wettability and water permeation.
- As a general rule under sink conditions, the rate at which the drug is released is directly proportional to the chewing frequency and aqueous solubility of drug substance and is indirectly proportional to the mass of the gum base.

IN VIVO 'CHEW-OUT' STUDIES

The in vivo release of active ingredient from chewing gum during mastication can be studied by recruiting a panel of sufficient numbers of tasters and scheduled chew-out studies. For the duration of the chewing process the drug contained within the MCG is released in the saliva and then it is either absorbed through oral mucosa or, if swallowed, it is absorbed through the gastrointestinal tract.

A. Release of drug in saliva: Panel of volunteers is asked to chew the drug delivery device for a certain period of time and to assess the remaining quantity of active substance in the residual gum. In this way, the gums are really chewed and the formulation is subjected not only to the mechanical stresses of an artificial machine but also it undergoes all the phenomena involved in this process (increase of salivary secretion, saliva pH variation, swallowing and absorption by the oral mucosa, etc.) which can strongly influence the performance of the dosage form and the amount and rate of drug release. Optimized formulation with good consistency can be selected for the release of drug in saliva. Minimum Four human volunteers can be selected (two male and two female). Volunteers are instructed to rinse their mouth with distilled water and allowed to chewing the medicated chewing gum for 15 minutes, so that its maximum release has to be taken. Sample of saliva are taken after 2, 4, 6, 8, 10, 12, 14, 15 min. The saliva samples are made diluted in required solvent and absorbance is analyzed by suitable analytical method³⁹

B. Dissolution test of residual medicated chewing gum

In this experiment, gums are tested by a panel of volunteers to verify the drug release process from the drug delivery system. Each person chews one sample of the tableted gum for different time periods (1, 5, 10, 15 min).⁴⁰ The residual gums are cut into small pieces, frozen and then ground till obtaining a fine powder. The residual drug content is determined by using suitable analytical method. The amount of drug released during mastication is calculated by subtracting the amount of residual active ingredient present in the gum from the total content, whereas pharmacokinetics can be determined from withdrawn blood samples at specific time intervals. The prerequisites of human volunteers, person-to-person variability in the chewing pattern, chewing frequencies, composition of individual salivary fluid and flow rate of saliva are a few limitations of chew-out studies.

C. Urinary excretion profile of medicated chewing gum

This method can be applicable only to those drugs which are excreted via urine. In that minimum four healthy human volunteer are selected for the study of formulations. Volunteers are strictly instructed that they should not take any medicine in the last 48 hour. They are fasted overnight, and emptied their bladder in the volumetric flask. Sample collection starts from blank of zero hour urine. Then sample collection is done on the 15 min, 1, 2, 3, 4, 6, 7, 8, 10, 11, 12, 24 hour intervals after administration of medicated chewing gum. The volunteers are asked to drink water at regular intervals of 30 min. and urine samples are analyzed by suitable analytical methods.

D. Buccal absorption test

Human volunteer swirled fixed volume of drug solution of known concentration at different pH value of 1.2, 5, 6, 6.5, 7, 7.5, 7.8, 8, in the oral cavity for 15 min and then expelled out. The expelled saliva is analyzed for drug back calculated for buccal absorption.⁴¹

Table No.1: Formulation of medicated chewing gum

S.No	Composition of medicated chewing gum	Objective	Examples
1	Elastomers	Provides elasticity, gummy texture and cohesion to the chewing gum	Natural elastomer: Natural rubbers like Latex or Natural gums such as Jelutong, Lechi Caspi, Perillo, and Chicle. Synthetic elastomers like polyisobutylene and butyl rubber are used.
2	Plasticizers	To regulate cohesiveness of product	Natural Plasticizers include Natural rosin esters like Glycerol Esters or Partially hydrogenated Rosin, Glycerol Esters of Polymerized Esters, Glycerol Esters of Partially dimerized Rosin and Pentaerythritol Esters of resin. Synthetic Plasticizers include Terpene Resins derived from α - pinene and or d-limonene.
3	Resins	As mastication substance and as binding agent between elastomers and fillers balance between the properties of elasticity and plasticity	Natural resins Glycerol esters from pine resins Synthetic resin polyvinyl acetate
4	Emulsifiers and fats	Soften the mixture and give the required chewing consistency and mouth feel Emulsifiers promote the uptake of saliva into the chewing gum during mastication	Emulsifiers: Monoglycerides, diglycerides and partly hardened vegetable and animal fat Softeners include Glycerin, Lecithin, Tallow, Hydrogenated Tallow, Mono/ di/ tri-Glycerides, Fatty acids like Stearic acid, Palmitic acid, Oleic acid and Linoleic acid.
5	Fillers or Texturizers	Provide the right texture, improve chewability, and provide reasonable size	Magnesium and Calcium Carbonate, Ground Limestone, Magnesium and Aluminium Silicate, Clay, Alumina, Talc, Titanium Oxide and Mono/ di/ tri Calcium Phosphate
6	Antioxidants	To protect the gum base and flavours from oxidation	Ascorbic acid, tocopherol, butylhydroxytoluene have been used.
7	Sweeteners	Provide longer lasting sweetness and flavour perception Aqueous Sweeteners can be used as softeners to blend the ingredients and retain moisture	Aqueous Sweeteners: Sorbitol, hydrogenated Starch hydrolysates and Corn Syrups Bulk Sweeteners : <i>Sugar Components</i> include Saccharides like Sucrose, Dextrose, Maltose, Dextrin, Fructose, Galactose, Corn Syrup <i>Sugarless Components</i> include sugar alcohols such as Sorbitol, Mannitol, Xylitol, hydrogenated Starch hydrolysate High intensity artificial Sweeteners:

			Sucralose,Aspartame, salt of Acesulfame, Alitame, Saccharin,Glycerrhizin, Dihydrochalcones
8	Colourants and Whiteners	Gives the formulation soothing colour and improves acceptability of the formulation	FD and C type dyes and lakes, fruit and vegetable extracts, Titanium Dioxide.
9	Flavouring Agents	To enhance consumer acceptability	Essential oils such as Citrus oil, fruit essences, Peppermint oil, Spearmint oil, Mint oil, Clove oil and Oil of Wintergreen. Artificial flavouring agents can also be used
10	Anti-caking agent	Prevent agglomeration of the subsequently ground chewing gum particles	Precipitated silicon dioxide ,solid carbon dioxide
11	Grinding agents	Prevent the gum from sticking to the grinding apparatus	Alkaline metal phosphate, an alkaline earth metal phosphate or malto dextrin
12	Compression adjuvant	To ease the compression process	Silicon dioxide, magnesium stearate, calcium stearate, talc ^{23,24}

Table No.2: Limitations of conventional/traditional method and freezing, grinding & tableting method of chewing gum preparation ¹⁴

S.No	Manufacturing method	Limitation
1	Conventional/ traditional method	Manufacturing of thermolabile may become challenging as elevated temperature is required during melting; If the gum is highly viscous, accurate dosing is not possible; Lack of precise form, shape, weight of dosage form; Grinding and compression: difficult to formulate chewing gum as tablets due to high moisture content.
2	Freezing, grinding and tableting method	High-tech, expensive equipments are required; Careful monitoring of humidity during manufacturing process becomes a challenge

Table No.3: Therapeutic uses of medicated chewing gums

S.No	Therapeutic uses	Specific example
1	Oral antifungal	Econazole ⁴² , Nystatine ⁴³ and Miconazole ^{44,45,46}
2	Smoking cessation	Nicotine ^{47,48} , and Silver acetate ⁴⁹
3	Pain relievers	Aspirin and Methadone ^{50,51,52}
4	CNS stimulation improvement of memory	Caffeine ⁵³
5	Treatment of otitis media	Xylitol ^{54,55}
6	Treatment for dental caries	Chlorhexidine ⁴
7	Treatment and management of motion sickness	Dimenhydrinate ⁵⁶
8	Acid neutralization	Antacid ⁵⁷
9	Treatment of vitamin C deficiency	vitamin C

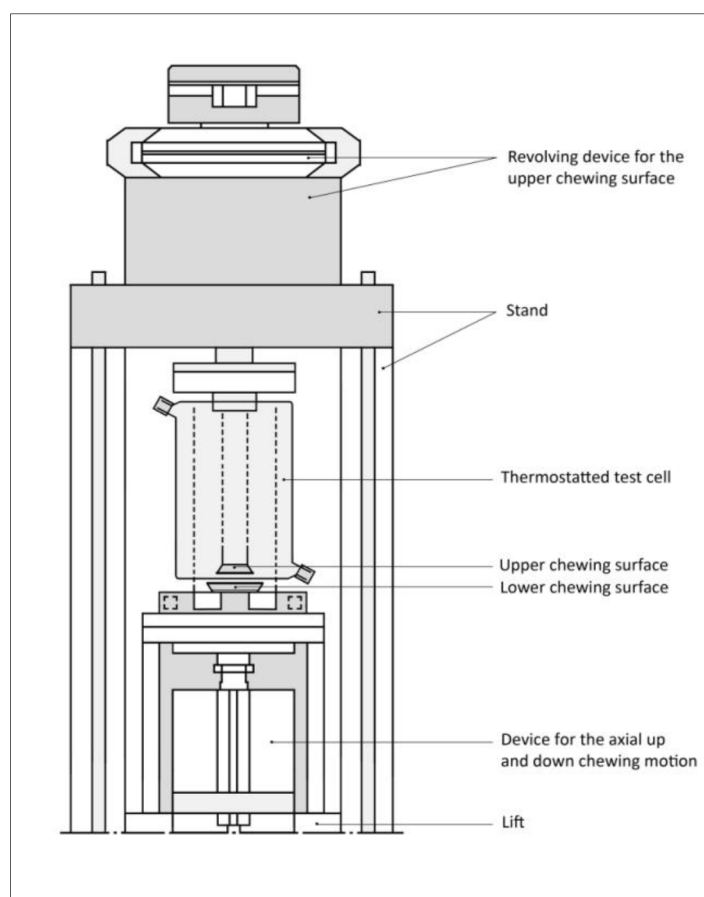

Figure No.1

Figure No.1: Schematic diagram of chewing apparatus

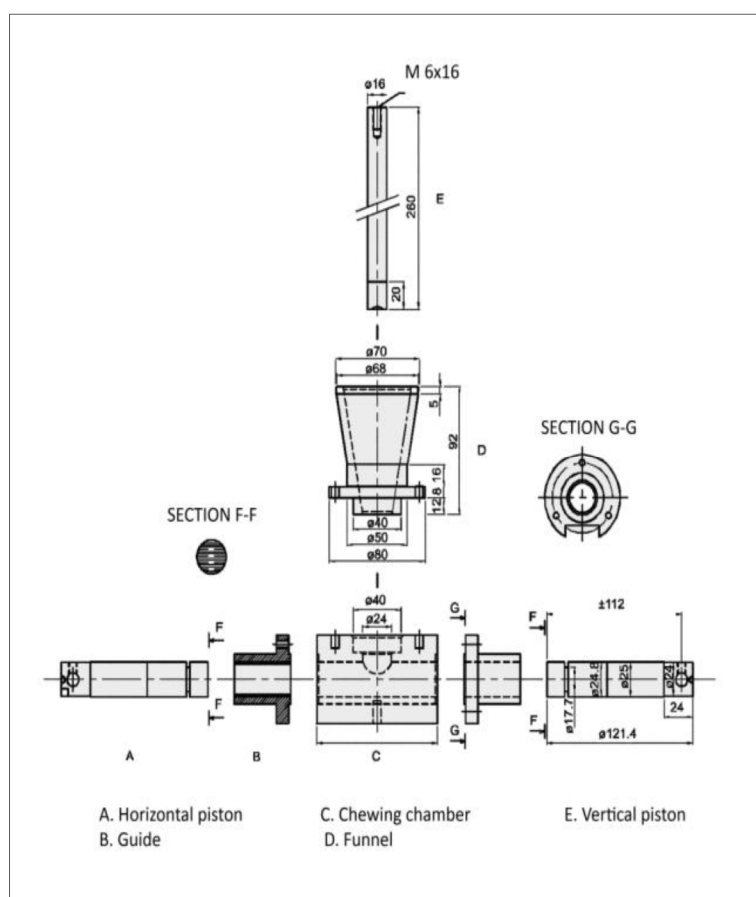

Figure No.2

Figure No.2: Schematic diagram of single-module chewing *in vitro* drug release study from medicated chewing gum apparatus for invitro drug release for medicated gum.

CONCLUSION

Medicated chewing gums could be a great way of delivering drug to the body either for local or systemic effect. The preparation procedure is easy and the dosage form is convenient to use, has got great patient compliance. The mouth freshening effect also adds some advantages. But quality testing procedures are not still well developed. The USP does not have any official method of *in vitro* drug release study. So evaluation of the prepared chewing gums is one of the major challenges.

ACKNOWLEDGEMENT

I am thankful to Seven Hills College of Pharmacy, Tirupati, Andhra Pradesh, India for providing facility to carry out the review work.

CONFLICT OF INTEREST

We declare that we have no conflict of interest.

REFERENCES

1. Chien Y W. Novel Drug Delivery Systems, Revised and Expanded, *Marcel Dekker, New York*, 2nd edition, 1992, 139-40.
2. Ghosh T K, Pfister W R. Drug delivery to the oral cavity molecules to market, *Taylor and Francis*, 2005.
3. Rama Bukka *et al.* Preparation and Evaluation of Intraoral Drug Delivery System for Rasagiline mesylate, *International Journal of Pharmaceutical Sciences and Drug Research*, 2(4), 2010, 294.
4. Imfeld T. Chewing gum-facts and fiction: a review of gum-chewing and oral health, *Crit Rev Oral Biol Med*, 10(3), 1999, 405-419.
5. Wilkinson L, Scholey A, Wesnes K. Chewing gum selectively improves aspects of memory in healthy volunteers, *Appetite*, 38(3), 2002, 235-236.
6. Shojaei A H. Buccal Mucosa as a Route for Systemic Drug Delivery: A Review, *J Pharm Pharmaceut Sci*, 1(1), 1998, 15-30.
7. Surana A S. Chewing gum: a friendly oral mucosal drug delivery system, *International Journal of Pharmaceutical Sciences Review and Research*, 4(2), 2010, 68-71.
8. Batra A, Klingler K, Landfeldt B, Friedrich H M, Westin A, Danielsson T. Smoking reduction treatment with 4-mg nicotine gum: a double-blind, randomized, placebo-controlled study, *Clin Pharmacol Ther*, 78(6), 2005, 689-696.
9. Moore M, Hasler-Nguyen N, Saroea G. *In vitro* tooth whitening effect of two medicated chewing gums compared to a whitening gum and saliva. *BMC Oral Health*, 8(1), 2008, 23.
10. Mehta F, Keservani R K, Karthikeyan C, Trivedi P. Chewing gum as a drug delivery system, *Archives of Applied Science Research*, 2(2), 2010, 79-99.
11. Naik Heema, Gupta Stuti. Medicated Chewing Gums - Updated Review, *International Journal of Pharmaceutical Research and Development*, 2(11), 2010, 66-76.
12. Shivang A Chaudhary and Aliasgar F Shahiwala. Medicated chewing gum a potential drug delivery system, *Expert Opin. Drug Deliv*, 7(7), 2010, 871-85.
13. Rassing M R. Specialized Oral Muccosal Drug Delivery, *Marcel Dekker, New York*, 1996, 319-57.
14. Heema N, Stuti G. Medicated Chewing Gums - Updated Review, *International Journal of Pharmaceutical Research and Development*, 2(8), 2010, 66-76.
15. Jacobsen J, Christrup L L, Jensen N H. Medicated Chewing Gum, *Am J Drug Deliv*, 2 (2), 2004, 75-88.
16. Goldberg L D, Ditchek N T. Chewing gum diarrhea, *Am J Dig Dis*, 23(6), 1978, 568-568.
17. Addy M, Roberts W R. Comparison of the bisbiguanide antiseptics alexidine and chlorhexidine, *J Clin Periodontol*, 8(3), 1981, 220-30.
18. Munksgaard E C, Nolte J, Kristensen K. Adherence of chewing gum to dental restorative materials, *Am J Dent*, 8(3), 1995, 137-139.
19. Weil A T. Coca leaf as a therapeutic agent, *Am J Drug Alcohol Abuse*, 5(1), 1978, 75-86.

20. Squier C A. The permeability of oral mucosa, *Critical reviews in oral biology and medicine*, 2(1), 1991, 13-32.
21. Basani Gavaskar *et al.* Medicated Chewing Gum- A Novel Approach to improve Patient Compliance, *International Journal of Pharmaceutical Sciences and Drug Research*, 2(4), 2010, 294.
22. Ezhumalai K *et al.* medicated chewing gum - a novel drug delivery for systematic and targeted drug delivery system, *International Journal of Pharmacy and Technology*, 3(1), 2011, 725-744.
23. Zyck D J, Greenberg M J, Barkalow D G, Marske S W, Schnell P G, Mazzone P, *et al.* Method of making coated chewing gum products containing various antacids, *US Patent* 6, 2003, 645.
24. Athanikar N K, Gubler S A. Process for manufacturing a pharmaceutical chewing gum, *US Patent*, 6, 2001, 322.
25. Athanikar N K, Gubler S A. Process for manufacturing a pharmaceutical chewing gum, *US Patent*, 98(4), 2004, 423-428.
26. Dodds M, Hiesh S, Johnson D. The effect of increased mastication by daily gum chewing on salivary gland output and dental plaque acidogenicity, *J Dent Res*, 70(12), 1991, 1474-1478.
27. Lichtneckert S, Lundgren C. and Ferno O. Chewable smoking substitute composition, *U.S. Patent*, 46(3), 1975, 321-327.
28. European Pharmacopoeia. Strasbourg, European Directorate for the Quality of Medicines, Chewing Gums, *Medicated*, 5th edition, 2004.
29. <http://www.fertin.com>.
30. http://www.fertin.com/fileadmin/pdf/Chewing_gum_as_a_DDS.pdf.
31. Jacobsen J, Christrup LL, Jensen NH. Medicated Chewing Gum: Pros and Cons. *Am J Drug Deliv*, 2 (2), 2004, 75-88.
32. Jacobsen J, Bjerregaard S, Pedersen M. Cyclodextrin inclusion complexes of antimycotics intended to act in the oral cavity drug supersaturation, toxicity on TR146 cells and release from a delivery system. *European Journal of Pharmacy and Biopharm*, 48(3), 1999, 217-24.
33. European pharmacopoeia, European Directorate for the Quality of Medicines, Council of Europe, 2000, 104.
34. European Directorate for the Quality of Medicines, Dissolution Test for Medicated Chewing Gums, *Strasbourg, France*, 5th edition, 2005, 3116-3117.
35. Kvist C, Andersson S B, Fors S, Wennergren B, Berglund J. Apparatus for studying *in vitro* drug release from medicated chewing gums, *International Journal of Pharmaceutics*, 189(1), 1999, 57-65.
36. Kvist L C, Andersson S B, Berglund J, Wennergren B, Fors S M. Equipment for drug release testing of medicated chewing gums, *Journal of Pharmaceutical Biomedical Analysis*, 22(3), 2000, 405-411.
37. European Directorate for the Quality of Medicines, Dissolution Test for Medicated Chewing Gums, *Strasbourg, France*, 6th edition, 2008, 304-306.
38. Upendra nagaich, Vandana chauthary, Roopa karki, Akash yadav, Praveen Sharma. Formulation of medicated chewing gum of on dansetron hydrochloride and its pharmacokinetic evaluations, *International journal of pharmaceutical sciences and research*, 1(2), 2010, 32-39.
39. Maggia L, Segalea S, *et al.* Preparation and evaluation of release characteristics of 3TabGum, a novel chewing device, *European Journal of Pharmaceutical Sciences*, 27, 2005, 487-93.
40. Gadhavi A G, *et al.* Medicated Chewing Gum - A 21st Century Drug Delivery System, *international journal of pharmaceutical science and research*, 2(8), 2011, 1961-1974.
41. Jacobsen J, Bjerregaard S, Pedersen M. Cyclodextrin inclusion complexes of antimycotics intended to act in the oral cavity drug super saturation, toxicity on TR146 cells and re-release from a delivery system, *Eur J Pharm Biopharm*, 48(3), 1999, 217-24.

42. Andersen T, Gram-Hansen M, Pedersen M, Rassing M R. Chewing Gum as a Drug Delivery System for Nystatin Influence of Solubilising Agents Upon the Release of Water Insoluble Drugs, *Drug Development and Industrial Pharmacy*, 16(13), 1990, 1985-1994.
43. Pedersen M, Rassing M R. Miconazole chewing gum as a drug delivery system test of release promoting additives, *Drug Dev Ind Pharm*, 16 (1), 1990, 55-74.
44. Rindum J, Hoimstrup P, Pederson M, Masing M, Stoltze K. Miconazole chewing gum for treatment of chronic oral candidosis, *Scand J Dent Res*, 101(6), 1984, 386-390.
45. Bastian H L, Rindum J, Lindeberg H. A double-dummy, double-blind, placebo-controlled phase III study comparing the efficacy and efficiency of miconazole chewing gum with a known drug (Brentan gel) and a placebo in patients with oral candidosis, *Oral Surg Oral Med Oral Pathol Oral Radiol Endod*, 98(4), 2004, 423-428.
46. Jensen E J, Schmidt E, Pedersen B, Dahl R. The effect of nicotine, silver acetate, and placebo chewing gum on the cessation of smoking, The influence of smoking type and nicotine dependence, *Psychopharmacology*, 104(4), 1991, 1223-1231.
47. Peters M J, Morgan L C. The pharmacotherapy of smoking cessation, *Med J Aust*, 176(10), 2002, 486-490.
48. Malcolm R, Currey H S, Mitchell M A, Keil J E. Silver acetate gum as a deterrent to smoking, *Chest*, 90(1), 1986, 107.
49. Bousquet E, Tirendi S, et al. Bioavailability of two formulations of acetylsalicylic acid gums, *Pharmazie*, 47(8), 1992, 607-609.
50. Christrup L L, Rassing M R. Chewing gum as a drug delivery system: influence of the formulation upon the rate of release of salicylamide, *Farmaci Sci*, 16, 1988, 1-5.
51. Hodoba D. Chewing can relieve sleepiness in a night of sleep deprivation, *Sleep Res Online*, 2(4), 1999, 101-105.
52. Kamimori G H, Karyekar C S, Otterstetter R. The rate of absorption and relative bioavailability of caffeine administered in chewing gum versus capsules to normal healthy volunteers, *International Journal of Pharmaceutics*, 234(1-2), 2002, 159-167.
53. Uhari M, Kontiokari T, Niemela M. A novel use of xyli-tol sugar in preventing acute otitis media, *Pediatric*, 102(4 Pt1), 1998, 879-84.
54. Skofitsch G, Lembeck F. Serum levels of dimenhydrinate, Determination by HPLC with UV detection after intake of dimenhydrinate in a coated chewing gum dragee, *Arznei-mittel for schung*, 33(12), 1983, 1674-6.
55. Seibel K, Schaffler K, Reitmeir P, Golly I. A randomised, placebo-controlled study comparing two formulations of dimenhydrinate with respect to efficacy in motion sickness and sedation, *Arzneimittel for schung*, 52(7), 2002, 529-36.
56. Bhise K S, Jahagirdar S. Medicated chewing gum: a re-view, *Indian J Pharm Educ*, 39(3), 2005, 139-146.

Please cite this article in press as: Shahid Mohammed S and Niranjan Babu M. Medicated chewing gum - an overview, *International Journal of Research in Pharmaceutical and Nano Sciences*, 3(4), 2014, 277-289.